

PROJECT :
 LAND DEVELOPMENT WORK FOR
 WAREHOUSE

LOCATION
 GODAWARI MUNICIPALITY - 1,
 KAILALI

DESIGNED BY :

CHECKED BY :

DATE : JULY-2024

SHEET TITLE :
 COMPOUND WALL LAYOUT PLAN

SCALE : --

SHEET NO. :
1

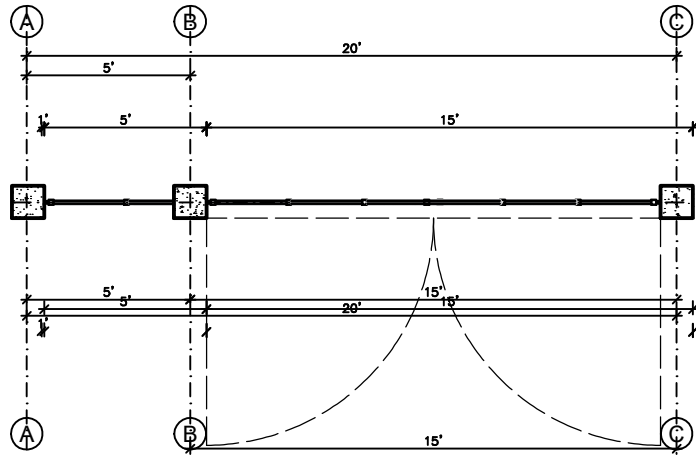

**MAIN ENTRANCE GATE
PLAN**

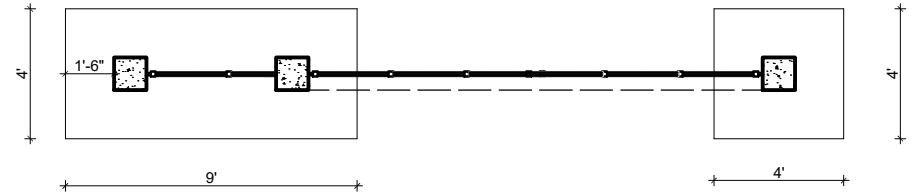

TRENCH PLAN FOR GATE COLUMN

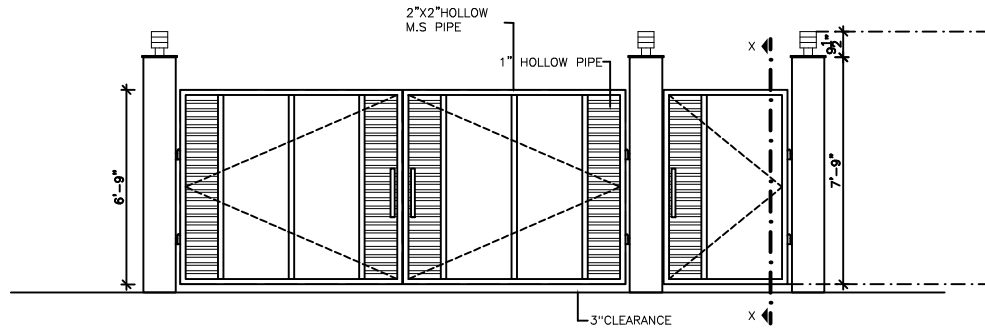

**MAIN ENTRANCE GATE
FRONT ELEVATION**

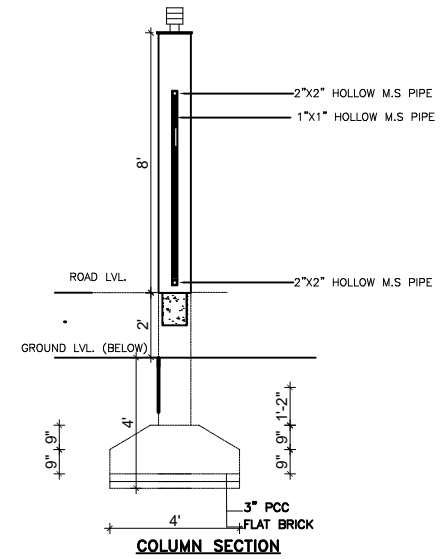

COLUMN SECTION



PROJECT :
LAND DEVELOPMENT WORK FOR
WAREHOUSE
LOCATION
GODAWARI MUNICIPALITY - 1,
KAILALI

DESIGNED BY :

CHECKED BY :

SHEET TITLE :
ENTRANCE GATE DETAILS

SHEET NO. :

DATE : JULY 2024

SCALE : --

2

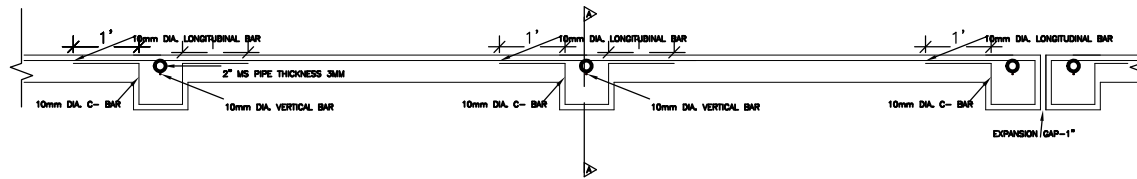

PLAN VIEW:- TOP BAND REINFORCEMENT DETAILING

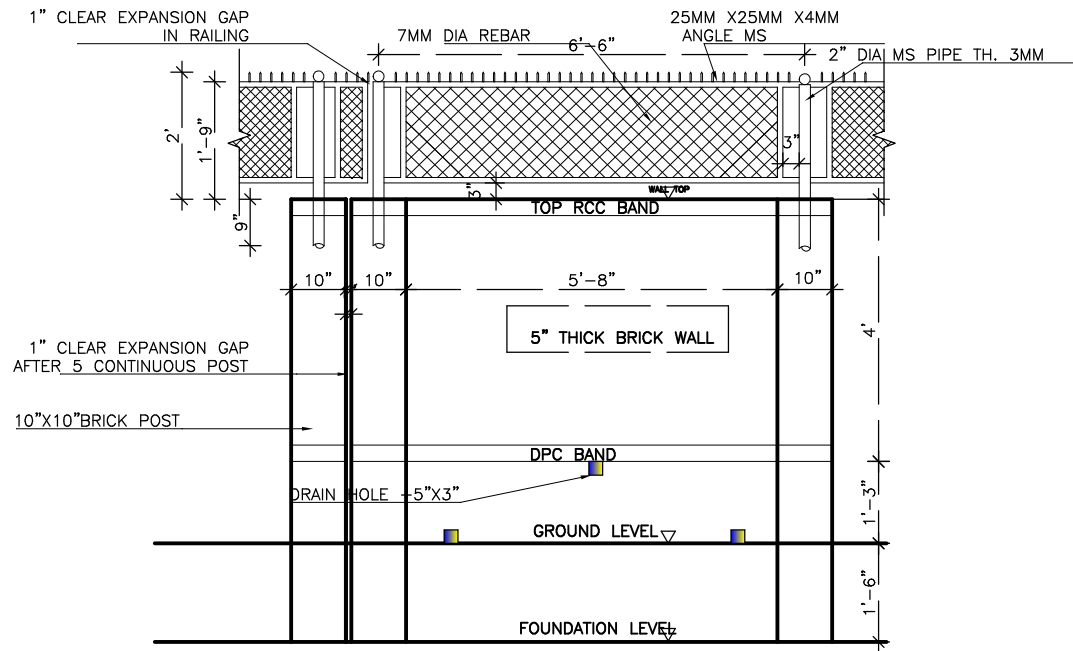

BOUNDARY WALL DETAILS



PROJECT :
LAND DEVELOPMENT WORK FOR
WAREHOUSE
LOCATION
GODAWARI MUNICIPALITY - 1,
KAILALI

DESIGNED BY :

CHECKED BY :

SHEET TITLE :

BOUNDARY WALL DETAILS

SHEET NO. :

3

DATE :25-MAY-2023

SCALE : 1":2'-0"

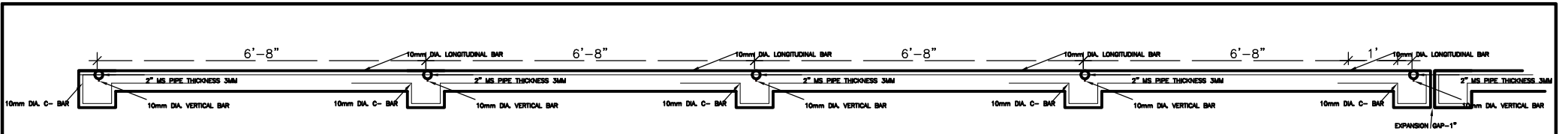

PLAN VIEW:— TOP BAND REINFORCEMENT DETAILING

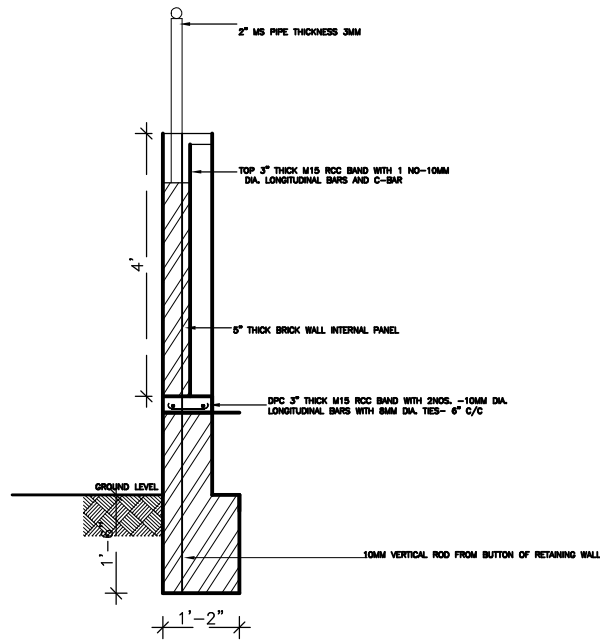

SECTION 1-1

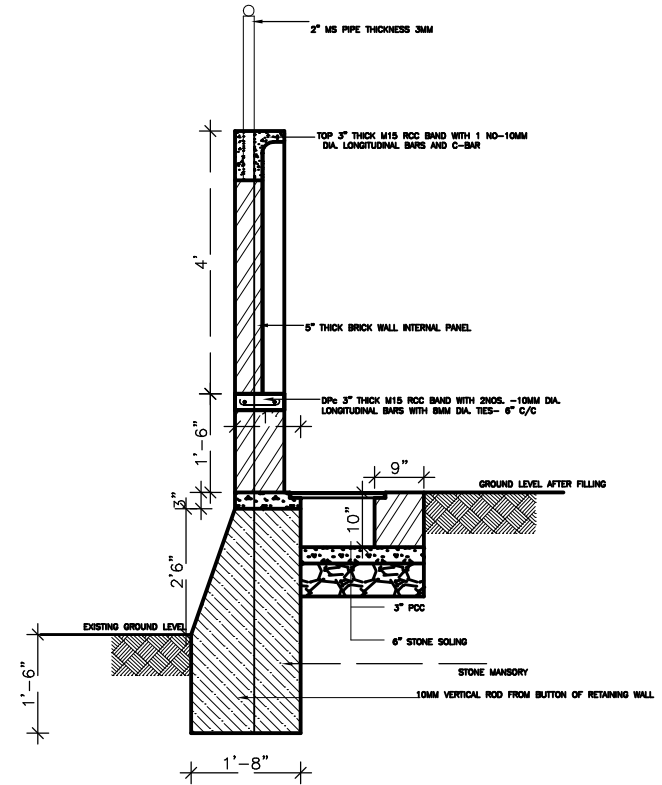

SECTION 2-2



PROJECT :
LAND DEVELOPMENT WORK FOR
WAREHOUSE
LOCATION
GODAWARI MUNICIPALITY - 1,
KAILALI

DESIGNED BY :

CHECKED BY :

SHEET TITLE :

BOUNDARY WALL DETAILS

SHEET NO. :

4

DATE :25-MAY-2023

SCALE : 1":2'-0"

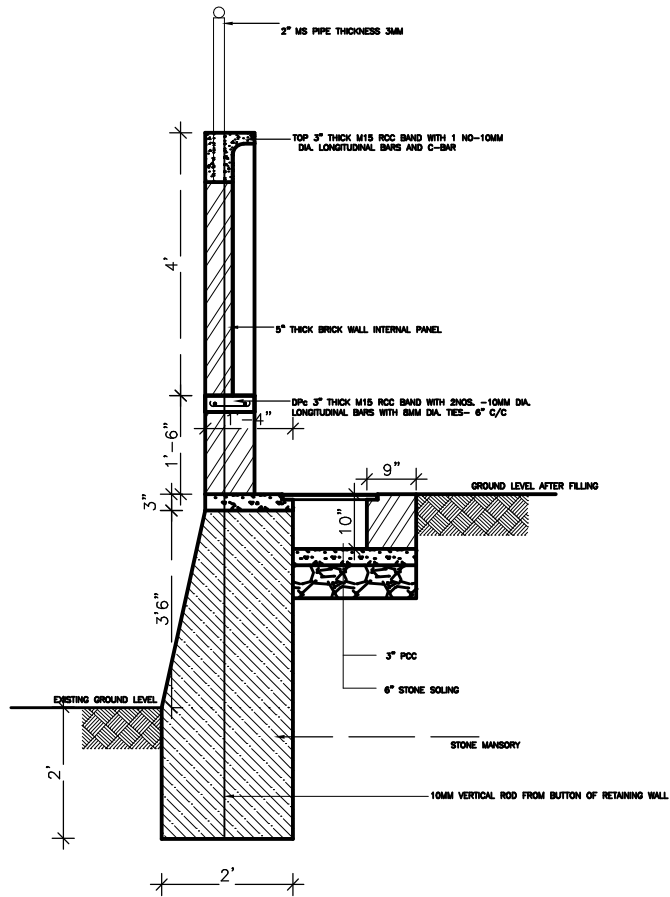

SECTION 3-3

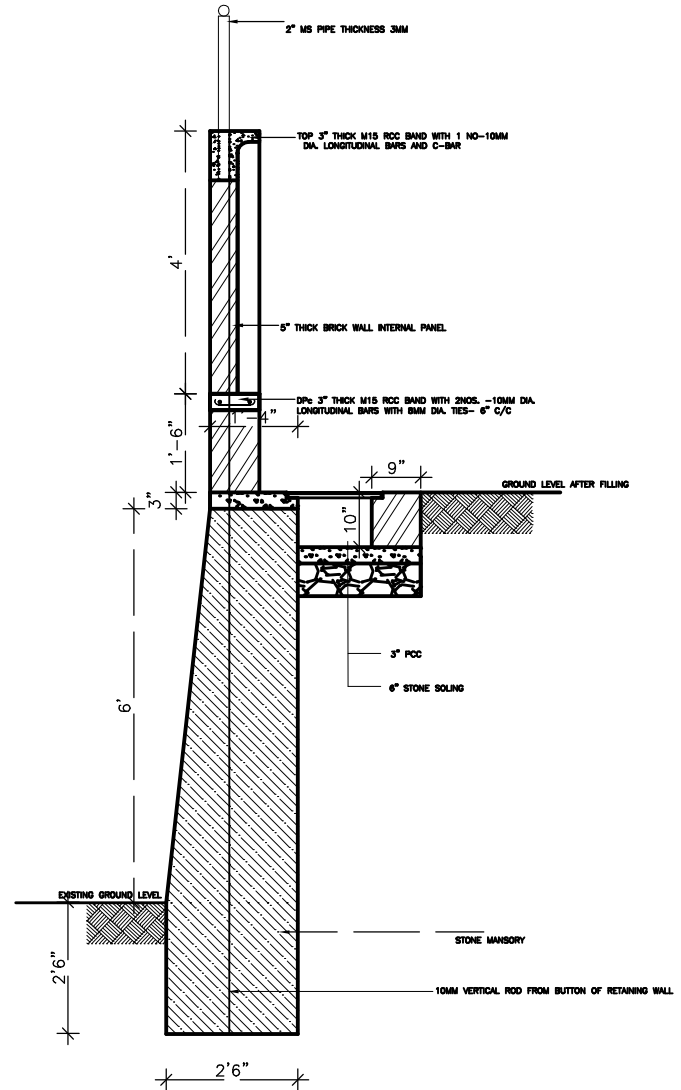

SECTION 4-4



PROJECT :
LAND DEVELOPMENT WORK FOR
WAREHOUSE
LOCATION
GODAWARI MUNICIPALITY - 1,
KAILALI

DESIGNED BY :

CHECKED BY :

SHEET TITLE :
BOUNDARY WALL DETAILS

SHEET NO. :

DATE :25-MAY-2023

SCALE :

5